

Compashield® splice quality requirements:

No reduction of the shielding properties in the splicing area. Splicing rubber thin and conductive.
 No flash, porosity or excess rubber at the joint after splicing.
 Max increase of compression force in the splicing area 5%. No excess splicing rubber inside hollow profiles.
 Jointing point should stand for 10% stretch without mechanical damage

Cross-section area

8.90 mm ²

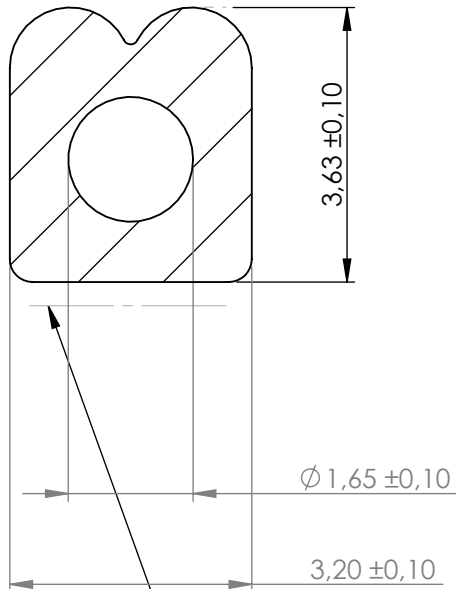
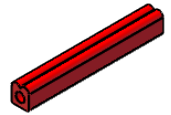

Adhesive on this side

Art.nr	Material	Lenght	Weight/m	Splice
9000134	Adhesive tape			
1213800	1540	Roll	9,79 g	No
1213801		545 +0/-5 mm		Yes
1213802		1375 ±5 mm		Yes
1213803		1000 +0/-10		Yes
1213804		1070 +0/-5		Yes
1213805		1245 +0/-5		Yes
1213806		1030 +0/-5		Yes
1213807		1095 +0/-5		Yes
1213808		173,7 ±2mm		Yes
1213809		804,9 ±3mm		Yes
1213810		918 ±3mm		Yes
1213811		1335 ±5mm		Yes
1213812		995 ±3mm		Yes
1213813		1235 ±5mm		Yes
1213814		1308 ±5mm		Yes
1213815		1216 ±5mm		Yes
1213816		1305 ±5mm		Yes
1213817		575,5 ±5mm		No
1213818		1151 ±10mm		x2*
1213819		782,5 ±2,5mm		Yes
1213820*		390 ± 3mm		Yes
1213821		1100 ±5 mm		Yes
1213822		168 ±5mm		Yes
1213823		310,5 ±5mm		Yes
1213824		824 ±5mm		Yes

REVISIONS

REV.	DATE	DESCRIPTION
E	14-02-06	Adhesion included on the gasket
Y	16-11-07	*1213818 must be delivered with 2 splicing joints i.e. 2x1213817 must be spliced together to a total length of 1151 ± 10mm
AB	3/6/2017	New splicing length added 1213820 without adhesive tape
AD	2017-07-24	Change of splicing length at 1213821 to 1100mm



Document name

Compashield Special Profile

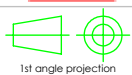

Sheet scale
10:1

Sheet size
A4

Document no.
P2138:13:001

Rev no.
AE

Nolato art. no.
1213800

Customer no.

General tolerances

Drawn by
S.Muhonen

Checked by
P.Brock

Date
2016-03-16

ISO 3302-1 M3

Reference cad data

Part version no.