

Compashield® splice quality requirements:

No reduction of the shielding properties in the splicing area. Splicing rubber thin and conductive.
No flash, porosity or excess rubber at the joint after splicing.
Max increase of compression force in the splicing area 5%. No excess splicing rubber inside hollow profiles.
Joining point should stand for 10% stretch without mechanical damage

Cross-section area
28.86 mm ²

Electrial resistance measure:

Methode: Nolato R3 Max:150 mOhm

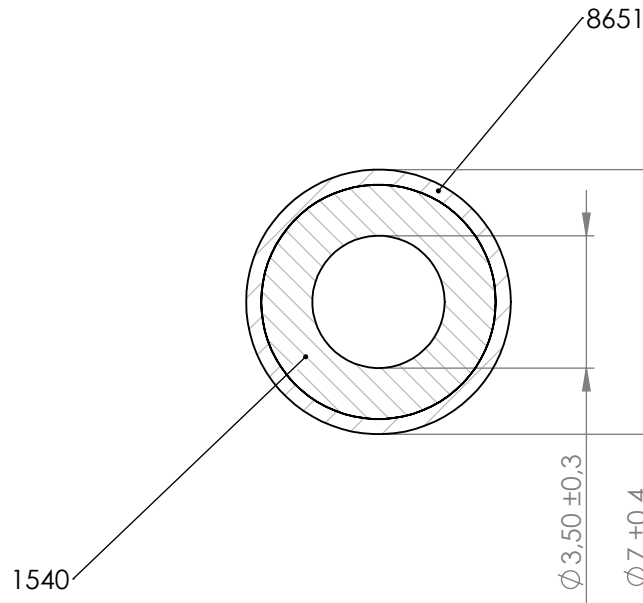

REVISIONS			Art.nr	Material	Lenght	Weight/m	Splice
REV.	DATE	DESCRIPTION	1191200	8651/1540	Roll	18g / 25g	No
B	130326	Minor changes					

		Document name Compashield Soft Hollow O-shape					
	Sheet scale 10:1	Sheet size A4	Document no. P1912:12:001	Rev no. C	Nalato art. no. 1191200	Customer no.	
General tolerances ISO 3302-1 M3			Drawn by T.Nilsson		Checked by		Date 2011-01-14
Reference cad data					Part version no.		