

Compashield® splice quality requirements:

No reduction of the shielding properties in the splicing area. Splicing rubber thin and conductive.
 No flash, porosity or excess rubber at the joint after splicing.
 Max increase of compression force in the splicing area 5%. No excess splicing rubber inside hollow profiles.
 Joining point should stand for 10% stretch without mechanical damage

Cross-section area6.01mm²**Electrial resistance measure:**

Methode: Nolato R3 Max:300 mOhm

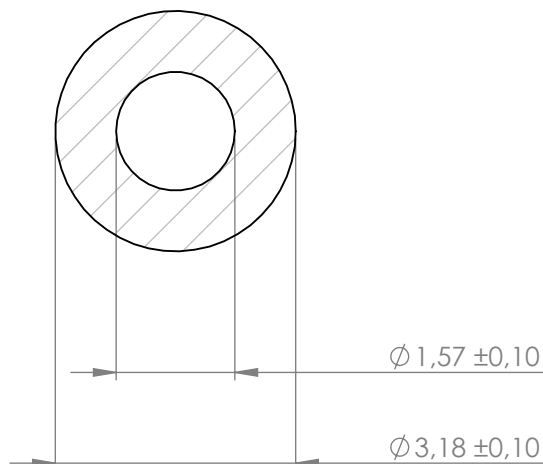
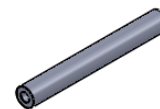

REVISIONS			Art.nr	Material	Lenght	Weight/m	Splice
REV.	DATE	DESCRIPTION	1153100	8642	Roll	13g	No
			1153101	8642	565 mm		Yes

**Nolato**

Document name

Compashield Hollow O-shape

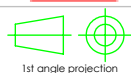

1st angle projection

Sheet scale
10:1Sheet size
A4Document no.
P1531:10:001Rev no.
BNolato art. no.
1153100

Customer no.

General tolerances

Drawn by
T.Nilsson

Checked by

Date
2010-01-27

SS-ISO 2768 m

Reference cad data

Part version no.