

**Compashield® splice quality requirements:**

No reduction of the shielding properties in the splicing area. Splicing rubber thin and conductive.  
 No flash, porosity or excess rubber at the joint after splicing.  
 Max increase of compression force in the splicing area 5%. No excess splicing rubber inside hollow profiles.  
 Joining point should stand for 10% stretch without mechanical damage

**Cross-section area**7,08 mm<sup>2</sup>**Electrial resistance measure:**

Methode: Nolato R3 Max: 300 mOhm

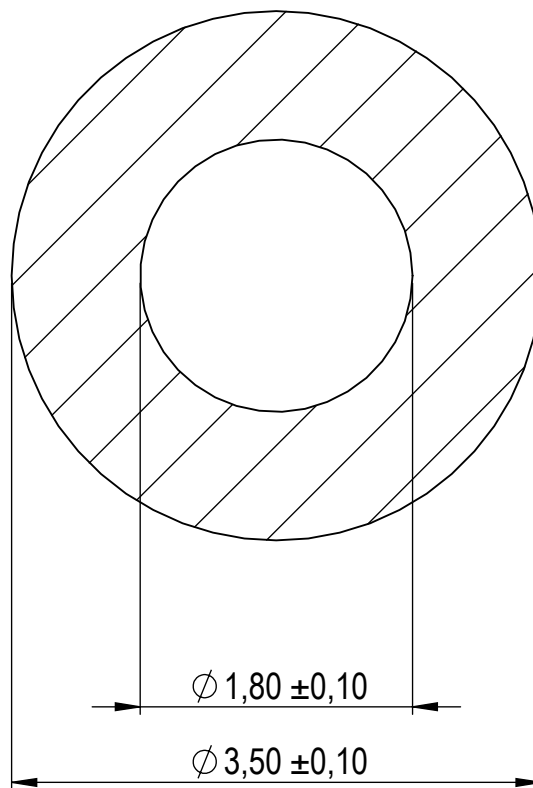

Art.nr	Material	Length	Weight/m	Splice
1266600	8642	Roll	17g	No

## REVISIONS

REV.	DATE	DESCRIPTION

**Nolato**

Document name

Compashield O-hollow Shape

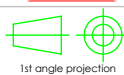

1st angle projection

Sheet scale  
20:1Sheet size  
A4Document no.  
P2666:16:001Rev no.  
BNolato art. no.  
1266600

General tolerances

Drawn by

K.L

Checked by

P.Å

Date

2015-03-05

SS ISO 3302-1 M3

Reference cad data

1266600 B Compashield O-hollow Shape